

# ISAF OFFSHORE SPECIAL REGULATIONS

## Extract for Race Category 3 Monohulls

### JANUARY 2008 - DECEMBER 2009

© ORC Ltd. 2002, all amendments from 2003 © International Sailing Federation,  
(IOM) Ltd.

**Version 1 – 2008**

#### ***Because this is an extract not all paragraph numbers will be present*** **Copyright**

When reprinting these regulations National Authorities and Race Organizers should :-

- request copyright permission from ISAF and ORC Ltd (normally given free of charge)
- display a copyright acknowledgement with the reprint (similar to © ORC Ltd. 2002, all amendments from 2003 © International sailing Federation, (IOM) Ltd.)
- make any amendments by deleting contrary provisions and indicating that changes have been made
- supply a copy of the reprint to each of ISAF and ORC Ltd

Official interpretations shall take precedence over these Special Regulations and will be indexed, numbered, dated and displayed on the ISAF web site

[www.sailing.org/specialregs](http://www.sailing.org/specialregs)

#### **Language & Abbreviations Used**

Mo - Monohull

Mu - Multihull

" \*\* " means the item applies to all types of yacht in all Categories except 5 or 6 for which see Appendix J or L.

**RED TYPE** indicates a significant changes in 2008

*Guidance notes and recommendations are in italics*

*The use of the masculine gender shall be taken to mean either gender*

#### **Administration**

*The Offshore Special Regulation are administered by the ISAF Special Regulation Sub-Committee whose terms of reference are as follows:  
([www.sailing.org/regulations](http://www.sailing.org/regulations))*

*ISAF Regulation 15.25.6 - The Special Regulations Sub-Committee shall:  
(a) be responsible for the maintenance, revision and changes to the ISAF Offshore Special Regulations governing offshore racing, under licence from ORC Ltd. Such changes shall be biennial with revised editions published in January of each even year, except that matters of an urgent nature affecting safety may be dealt with by changes to the Regulations on a shorter time scale;*

*(b) monitor developments in offshore racing relative to the standards of safety and seaworthiness.*

*Any queries please E-Mail: [technical@isaf.co.uk](mailto:technical@isaf.co.uk)*

## SECTION 1 - FUNDAMENTAL AND DEFINITIONS

### 1.01 Purpose and Use

- 1.01.1 It is the purpose of these Special Regulations to establish uniform minimum equipment, accommodation and training standards for monohull and multihull yachts racing offshore. A Proa is excluded from these regulations.
- 1.01.2 These Special Regulations do not replace, but rather supplement, the requirements of governmental authority, the Racing Rules and the rules of Class Associations and Rating Systems. The attention of persons in charge is called to restrictions in the Rules on the location and movement of equipment.
- 1.01.3 These Special Regulations, adopted internationally, are strongly recommended for use by all organizers of offshore races. Race Committees may select the category deemed most suitable for the type of race to be sailed.

### 1.02 Responsibility of Person in Charge

- 1.02.1 The safety of a yacht and her crew is the sole and inescapable responsibility of the person in charge who must do his best to ensure that the yacht is fully found, thoroughly seaworthy and manned by an experienced crew who have undergone appropriate training and are physically fit to face bad weather. He must be satisfied as to the soundness of hull, spars, rigging, sails and all gear. He must ensure that all safety equipment is properly maintained and stowed and that the crew know where it is kept and how it is to be used.**
- 1.02.2 Neither the establishment of these Special Regulations, their use by race organizers, nor the inspection of a yacht under these Special Regulations in any way limits or reduces the complete and unlimited responsibility of the person in charge.
- 1.02.3 Decision to race -The responsibility for a yacht's decision to participate in a race or to continue racing is hers alone - RRS Fundamental Rule 4.**

### 1.03 Definitions, Abbreviations, Word Usage

- 1.03.1 Definitions of Terms used in this document

TABLE 1

Age Date	Month/year of first launch
AIS	Automatic Identification Systems
CEN	Comité Européen de Normalisation
CPR	Cardio-Pulmonary Resuscitation
Coaming	includes the transverse after limit of the cockpit over which water would run in the event that when the yacht is floating level the cockpit is flooded or filled to overflowing.
DSC	Digital Selective Calling

EN	European Norm
EPFS	Electronic Position-Fixing System
EPIRB	Emergency Position-Indicating Radio Beacon
FA Station	The transverse station at which the upper corner of the transom meets the sheerline.
Foul-Weather Suit	A foul weather suit is clothing designed to keep the wearer dry and maybe either a jacket and trousers worn together, or a single garment comprising jacket and trousers.
GMDSS	Global Maritime Distress & Safety System
GNSS	Global Navigation Satellite System
GPIRB	EPIRB, with integral GPS position-fixing
ITU	International Telecommunications Union
GPS	Global Positioning System
Hatch	The term hatch includes the entire hatch assembly and also the lid or cover as part of that assembly (the part itself may be described as a hatch).
INMARSAT	This is Inmarsat Global Limited, the private company that provides GMDSS satellite distress and safety communications, plus general communications via voice, fax and data
IMO	International Maritime Organisation
IMSO	The International Mobile Satellite Organisation, the independent, intergovernmental organisation that oversees Inmarsat's performance of its Public Service Obligations for the GMDSS and reports on these to IMO
ISAF	International Sailing Federation.
ISO	International Standard or International Organization for Standardization.
Lifeline	wire line rigged as guardrail / guardline around the deck
LOA	Length overall not including pulpits, bowsprits, boomkins etc.
LWL	(Length of) loaded waterline
Monohull	Yacht in which the hull depth in any section does not decrease towards the centre-line.
Moveable Ballast	Lead or other material including water which has no practical function in the boat other than to increase weight and/or to influence stability and/or trim and which may be moved transversely but not varied in weight while a boat is racing.
ORC	Offshore Racing Congress (formerly Offshore Racing

	Council)
OSR	Offshore Special Regulation(s)
Permanently Installed	Means the item is effectively built-in by eg bolting, welding, glassing etc. and may not be removed for or during racing.
PLB	Personal Locator Beacon
Proa	Asymmetric Catamaran
RRS	ISAF - Racing Rules of Sailing
SAR	Search and Rescue
SART	Search and Rescue Transponder
Series Date	Month & Year of first launch of the first yacht of the production series
SOLAS	Safety of Life at Sea Convention
Safety Line	A tether used to connect a safety harness to a strong point
Securely Fastened	Held strongly in place by a method (eg rope lashings, wing-nuts) which will safely retain the fastened object in severe conditions including a 180 degree capsize and allows for the item to be removed and replaced during racing
Static Ballast	Lead or other material including water which has no practical function in the boat other than to increase weight and/or to influence stability and/or trim and which may not be moved or varied in weight while a boat is racing.
Static Safety Line	A safety line (usually shorter than a safety line carried with a harness) kept clipped on at a work-station
Variable Ballast	Water carried for the sole purpose of influencing stability and/or trim and which may be varied in weight and/or moved while a boat is racing.

1.03.2 The words "shall" and "must" are mandatory, and "should" and "may" are permissive.

1.03.3 The word "yacht" shall be taken as fully interchangeable with the word "boat".

## **SECTION 2 - APPLICATION & GENERAL REQUIREMENTS**

### **2.01 Categories of Events**

*In many types of race, ranging from trans-oceanic sailed under adverse conditions to short-course day races sailed in protected waters, six categories are established, to provide for differences in the minimum standards of safety and accommodation required for such varying circumstances:*

#### **2.01.4 Category 3**

Races across open water, most of which is relatively protected or close to shorelines.

### **2.02 Inspection**

A yacht may be inspected at any time. If she does not comply with these Special Regulations her entry may be rejected, or she will be liable to disqualification or such other penalty as may be prescribed by the national authority or the race organizers.

### **2.03 General Requirements**

2.03.1 All equipment required by Special Regulations shall:-

- a) function properly
- b) be regularly checked, cleaned and serviced
- c) when not in use be stowed in conditions in which deterioration is minimised
- d) be readily accessible
- e) be of a type, size and capacity suitable and adequate for the intended use and size of the yacht.

2.03.2 Heavy items:

- a) ballast, ballast tanks and associated equipment shall be permanently installed
- b) heavy movable items including e.g. batteries, stoves, gas bottles, tanks, toolboxes and anchors and chain shall be securely fastened
- c) heavy items for which fixing is not specified in Special Regulations shall be permanently installed or securely fastened, as appropriate

2.03.3 When to show navigation lights

- a) navigation lights (OSR 3.27) shall be shown as required by the International Regulations for Preventing Collision at Sea, (Part C and Technical Annex 1). All yachts shall exhibit sidelights and a sternlight at the required times.

## SECTION 3 - STRUCTURAL FEATURES, STABILITY, FIXED EQUIPMENT

### 3.01 Strength of Build, Ballast and Rig

Yachts shall be strongly built, watertight and, particularly with regard to hulls, decks and cabin trunks capable of withstanding solid water and knockdowns. They must be properly rigged and ballasted, be fully seaworthy and must meet the standards set forth herein. Shrouds shall never be disconnected.

### 3.02 Watertight Integrity of a Hull

- 3.02.1 A hull, including, deck, coach roof, windows, hatches and all other parts, shall form an integral, essentially watertight unit and any openings in it shall be capable of being immediately secured to maintain this integrity.
- 3.02.2 Centreboard and daggerboard trunks and the like shall not open into the interior of a hull except via a watertight inspection/maintenance hatch of which the opening shall be entirely above the waterline of the yacht floating level in normal trim.
- 3.02.3 A canting keel pivot shall be completely contained within a watertight enclosure which shall comply with OSR 3.02.2. Access points in the watertight enclosure for control and actuation systems or any other purpose shall comply with OSR 3.02.1.
- 3.02.4 Moveable ballast systems shall be fitted with a manual control and actuation secondary system which shall be capable of controlling the full sailing load of the keel in the event of failure of the primary system. Such failures would include electrical and hydraulic failure and mechanical failure of the components and the structure to which it mounts. The system must be capable of being operational quickly and shall be operable at any angle of heel. It would be desirable if this system was capable of securing the keel on the centreline.

### 3.04 Stability - Monohulls

- 3.04.2 A yacht shall be designed and built to resist capsize.
- 3.04.3 *A race organizer should require compliance with a minimum stability or stability/buoyancy index. Attention is drawn to the stability index in the ORC Rules and Regulations.*
- 3.04.4 *ISO 12217-2 may be used as a guide to general suitability for competition in Special Regulations race categories as follows:*
- 3.04.4 *Achievement of Design Category B under ISO 12217-2 may be accepted by a race organizer as a guide to general suitability for competition in a Special Regulations Category 3 race.*
- 3.04.5 *Use of the ISO or any other index does not guarantee total safety or total freedom of risk from capsize or sinking.*
- 3.04.6 For boats with moveable or variable ballast the method in OSR 3.04.4 shall apply plus the relevant additional requirement of OSR Appendix K.
- 3.04.7 Tanks for variable ballast shall be permanently installed and shall be provided with a system of isolating valves and pump(s) capable of

manual operation at any angle of heel. A plan of the plumbing system shall be displayed aboard the boat.

### 3.06 Exits - Monohulls

TABLE 4

LOA	Earliest of Age or Series Date	Detail
8.5 m (28 ft) and over	January 1995 and after	Yachts shall have at least two exits. At least one exit shall be located forward of the foremost mast except where structural features prevent its installation.

### 3.08 Hatches & Companionways

3.08.1 No hatch forward of the maximum beam station shall open in such a way that the lid or cover moves into the open position towards the interior of the hull (excepting ports having an area of less than 0.071m<sup>2</sup> (110 sq in)).

3.08.2 A hatch shall be:

a) so arranged as to be above the water when the hull is heeled 90 degrees. Hatches over lockers that open to the interior of the vessel shall be included in this requirement. A yacht may have a maximum of four (two on each side of centerline) hatches that do not conform to this requirement, provided that the opening of each is less than 0.071 sq m (110 sq in). Effective for boats of a series begun after January 1, 2009, a written statement signed by the designer or other person who performed the downflooding analysis shall be carried on board. For purposes of this rule the vessel's displacement condition for the analysis shall be the Light Craft Condition LCC (in conformity with 6.3 of the EN ISO 8666 standard and 3.5.1 of the EN ISO12217-2 standard).

b) permanently attached

c) capable of being firmly shut immediately and remaining firmly shut in a 180 degree capsized (inversion)

3.08.3 A companionway hatch extending below the local sheerline, shall:

a) not be permitted in a yacht with a cockpit opening aft to the sea (OSR 3.09.6)

b) be capable of being blocked off up to the level of the local sheerline, provided that the companionway hatch shall continue to give access to the interior with the blocking devices (e.g. washboards) in place

3.08.4 A companionway hatch shall:

a) be fitted with a strong securing arrangement which shall be operable from the exterior and interior including when the yacht is inverted

- b) have any blocking devices
  - i capable of being retained in position with the hatch open or shut
  - ii whether or not in position in the hatchway, secured to the yacht (e.g. by lanyard) for the duration of the race, to prevent their being lost overboard
  - iii permit exit in the event of inversion

### **3.09 Cockpits - Attention is Drawn to ISO 11812**

- 3.09.1 Cockpits shall be structurally strong, self-draining quickly by gravity at all angles of heel and permanently incorporated as an integral part of the hull.
- 3.09.2 Cockpits must be essentially watertight, that is, all openings to the hull must be capable of being strongly and rigidly secured
- 3.09.3 A bilge pump outlet pipe shall not be connected to a cockpit drain . See OSR 3.09.8 for cockpit drain minimum sizes
- 3.09.4 A cockpit sole shall be at least 2% LWL above LWL (or in IMS yachts first launched before 1/03, at least 2% L above LWL)
- 3.09.5 A bow, lateral, central or stern well shall be considered a cockpit for the purposes of OSR 3.09
- 3.09.6 In cockpits opening aft to the sea structural openings aft shall be not less in area than 50% maximum cockpit depth x maximum cockpit width.

#### **3.09.7 Cockpit Volume**

- i) earliest of age or series date before April 1992  
the total volume of all cockpits below lowest coamings shall not exceed 9% (LWL x maximum beam x freeboard abreast the cockpit).
- ii) earliest of age or series date April 1992 and after  
as above for the appropriate category except that "lowest coamings" shall not include any aft of the FA station and no extension of a cockpit aft of the working deck shall be included in calculation of cockpit volume

*IMS-rated boats may instead of the terms LWL, maximum beam, freeboard abreast the cockpit, use the IMS terms L, B and FA.*

#### **3.09.8 Cockpit Drains**

See OSR 3.09.1. Cockpit drain cross section area (after allowance for screens if fitted) shall be:-

- a) in yachts with earliest of age or series date before 1/72 or in any yacht under 8.5m (28ft) LOA - at least that of 2 x 25mm diameter (one inch) unobstructed openings or equivalent
- b) in yachts with earliest of age or series date 1/72 and later - at least that of 4 x 20mm diameter (3/4 inch) unobstructed openings or equivalent

### **3.10 Sea Cocks or Valves**

Sea cocks or valves shall be permanently installed on all through-hull openings below the waterline except integral deck scuppers, speed indicators, depth finders and the like, however a means of closing such openings shall be provided.

### 3.11 Sheet Winches

Sheet winches shall be mounted in such a way that an operator is not required to be substantially below deck.

### 3.12 Mast Step

The heel of a keel stepped mast shall be securely fastened to the mast step or adjoining structure.

### 3.14 Pulpits, Stanchions, Lifelines

3.14.2 Lifelines required in Special Regulations shall be "taut".

*a) As a guide, when a deflecting force of 50 N (5.1 kgf, 11.2 lbf) is applied to a lifeline midway between supports, the lifeline should not deflect more than 50 mm.*

3.14.3 The following shall be provided:

a) a bow pulpit with vertical height and openings essentially conforming to Table 7. Bow pulpits may be open but the opening between the pulpit and any part of the boat shall never be greater than 360mm (14.2") (this requirement shall be checked by presenting a 360mm (14.2") circle inside the opening)

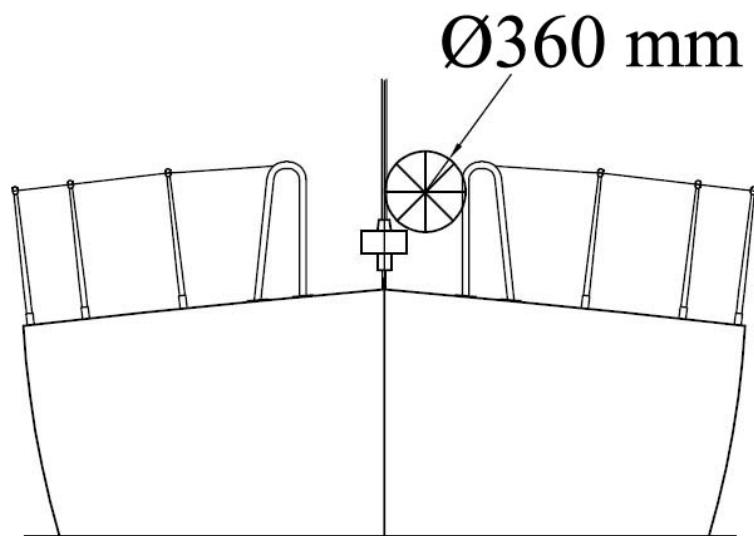

b) a stern pulpit, or lifelines arranged as an adequate substitute, with vertical openings conforming to Table 7

c) lifelines (guardlines) supported on stanchions, which, with pulpits, shall form an effectively continuous barrier around a working deck for man-overboard prevention. Lifelines shall be permanently supported at intervals of not more than 2.20m (86.6") and shall not pass outboard of supporting stanchions

- d) upper rails of pulpits at no less height above the working deck than the upper lifelines as in Table 7.
- e) Openable upper rails in bow pulpits shall be secured shut whilst racing
- f) Pulpits and stanchions shall be permanently installed. When there are sockets or studs, these shall be through-bolted, bonded or welded. The pulpit(s) and/or stanchions fitted to these shall be mechanically retained without the help of the life-lines. Without sockets or studs, pulpits and/or stanchions shall be through-bolted, bonded or welded.
- g) The bases of pulpits and stanchions shall not be further inboard from the edge of the appropriate working deck than 5% of maximum beam or 150 mm (6 in), whichever is greater.
- h) Stanchion bases shall not be situated outboard of a working deck. For the purpose of this rule a stanchion or pulpit base shall be taken to include a sleeve or socket into which a stanchion or pulpit tube is fitted but shall exclude a baseplate which carries fixings into the deck or hull.
- i) Provided the complete lifeline enclosure is supported by stanchions and pulpit bases effectively within the working deck, lifeline terminals and support struts may be fixed to a hull aft of the working deck
- j) Lifelines need not be fixed to a bow pulpit if they terminate at, or pass through, adequately braced stanchions set inside and overlapping the bow pulpit, provided that the gap between the upper lifeline and the bow pulpit does not exceed 150 mm (6 in).
- k) Stanchions shall be straight and vertical except that:-
  - i) within the first 50 mm (2 in) from the deck, stanchions shall not be displaced horizontally from the point at which they emerge from the deck or stanchion base by more than 10 mm (3/8 in),and
  - ii) stanchions may be angled to not more than 10 degrees from vertical at any point above 50 mm (2 in) from the deck.

*l) It is strongly recommended that designs also comply to ISO 15085*

### 3.14.5 Lifeline Height, Vertical Openings, Number of Lifelines

TABLE 7

LOA	earliest of age/seriesdate	minimum requirements	Category
under 8.5 m(28 ft)	before January 1992	taut single lifeline at a height of no less than 450 mm (18 in) above the working deck. No vertical opening shall exceed 560 mm (22 in).	**

under 8.5 m(28 ft)	January 1992 and after	as for under 8.5 m(28 ft) in table 7 above, except that when an intermediate lifeline is fitted no vertical opening shall exceed 380 mm (15 in).	**
8.5 m (28 ft) and over	before January 1993	taut double lifeline with upper lifeline at a height of no less than 600 mm (24 in) above the working deck. No vertical opening shall exceed 560 mm (22 in)	**
8.5 m (28 ft) and over	January 1993 and after	as 8.5 m (28 ft) and over in Table 7 above, except that no vertical opening shall exceed 380 mm (15 in).	**
all	all	on yachts with intermediate lifelines the intermediate line shall be not less than 230 mm (9 in) above the working deck.	**

### 3.14.6 Lifeline Minimum Diameters, Required Materials, Specifications

a) Lifelines shall be stranded stainless steel wire of minimum diameter in table 8 below. Lifelines shall be uncoated and used without close-fitting sleeving.

Notwithstanding 3.14.6 (a), temporary sleeving may be fitted provided it is regularly removed for inspection

*b) Grade 316 stainless wire is recommended.*

*c) A taut lanyard of synthetic rope may be used to secure lifelines provided the gap it closes does not exceed 100 mm (4 in). This lanyard shall be replaced annually at a minimum.*

d) All wire, fittings, anchorage points, fixtures and lanyards shall comprise a lifeline enclosure system which has at all points at least the breaking strength of the required lifeline wire.

TABLE 8

LOA	minimum wire diameter
under 8.5 m (28ft)	3 mm (1/8 in)
8.5m - 13 m	4 mm (5/32 in)
over 13 m (43 ft)	5 mm (3/16 in)

### 3.14.7 Pulpits, Stanchions, Lifelines - Limitations on Materials

TABLE 9

Earliest of Age or	detail
--------------------	--------

before January 1987	carbon fibre is not recommended in stanchions pulpits and lifelines.
January 1987 and	stanchions, pulpits and lifelines shall not be

### 3.17 Toe Rail or Foot - Stop

3.17.1 A toe rail of minimum height 25 mm (1 in) shall be permanently installed around the foredeck from abreast the mast, except in way of fittings and not further inboard from the edge of the working deck than one third of the local half-beam.

3.17.2 The following variations shall apply:-

TABLE 10

LOA	Earliest of Age or Series Date	minimum requirements
any	before January 1981	a toe rail minimum height of 20 mm (3/4 in) is acceptable.
any	before January 1993	an additional lifeline of minimum height 25 mm (1 in) and maximum height 50 mm (2 in) is acceptable in lieu of a toe rail (but shall not count as an intermediate lifeline).
any	January 1994 and after	the toe rail shall be fitted as close as practicable to the vertical axis of stanchion bases but not further inboard than 1/3 the local half-beam.

### 3.18 Toilet

3.18.2 A toilet, permanently installed or fitted bucket

### 3.19 Bunks

3.19.2 Bunks, permanently installed

### 3.20 Cooking Facilities

3.20.1 A cooking stove, permanently installed or securely fastened with safe accessible fuel shutoff control and capable of being safely operated in a seaway.

### 3.21 Drinking Water Tanks & Drinking Water

#### 3.21.1 Drinking Water Tanks

a) A yacht shall have a permanently installed delivery pump and water tank(s):

#### 3.21.3 Emergency Drinking Water

a) At least 9 litres (2 UK gallons, 2.4 US gallons) of drinking water for emergency use shall be provided in a dedicated and sealed container or container(s)

### 3.22 Hand Holds

Adequate hand holds shall be fitted below deck so that crew members

may move about safely at sea.

*A hand hold should be capable of withstanding without rupture a side force of 1500N - attention is drawn to ISO 15085.*

### **3.23 Bilge Pumps and Buckets**

- 3.23.1 No bilge pump may discharge into a cockpit unless that cockpit opens aft to the sea.
- 3.23.2 Bilge pumps shall not be connected to cockpit drains. (OSR 3.09)
- 3.23.3 Bilge pumps and strum boxes shall be readily accessible for maintenance and for clearing out debris
- 3.23.4 Unless permanently installed, each bilge pump handle shall be provided with a lanyard or catch or similar device to prevent accidental loss
- 3.23.5 The following shall be provided:
  - d) at least one permanently installed manual bilge pump operable with all cockpit seats, hatches and companionways shut
  - f) two buckets of stout construction each with at least 9 litres (2 UK gallons, 2.4 US gallons) capacity. Each bucket to have a lanyard.

### **3.24 Compass**

- 3.24.1 The following shall be provided:-
  - a) a marine magnetic compass, independent of any power supply, permanently installed and correctly adjusted with deviation card, and
  - b) a compass which may be hand-held

### **3.25 Halyards.**

No mast shall have less than two halyards, each capable of hoisting a sail.

### **3.27 Navigation Lights (see OSR 2.03.3)**

- 3.27.1 Navigation lights shall be mounted so that they will not be masked by sails or the heeling of the yacht.
- 3.27.2 Navigation lights shall not be mounted below deck level and should be at no less height than immediately under the upper lifeline.
- 3.27.3 Navigation light intensity

TABLE 11

<i>LOA</i>	<i>Guide to required minimum power rating for an electric bulb in a navigation light</i>
<i>under 12 m (39.4 ft)</i>	<i>10 W</i>
<i>12 m (39.4 ft) and above</i>	<i>25 W</i>

- 3.27.4 Reserve navigation lights shall be carried having the same minimum specifications as the navigation lights above, with a separable power source, and wiring or supply system essentially separate from that used for the normal navigation lights

3.27.5 spare bulbs for navigation lights shall be carried, or for lights not dependent on bulbs, appropriate spares.

### **3.28 Engines, Generators, Fuel**

3.28.1. A propulsion engine shall be provided, EITHER as a securely covered inboard engine together with permanently installed exhaust and fuel supply systems and fuel tank(s) OR as an outboard engine with associated tanks and fuel supply systems, all securely fastened.

3.28.2 A propulsion engine shall be provided, EITHER as a securely covered inboard engine together with permanently installed exhaust and fuel supply systems and fuel tank(s) OR in a multihull of less than 12.0m (39.4ft) as an outboard engine with associated tanks and fuel supply systems, all securely fastened.

a) A separate generator for electricity is optional. However, when a separate generator is carried it shall be permanently installed, securely covered, and shall have permanently installed exhaust and fuel supply systems and fuel tank(s). A separate generator shall comply with OSR 3.28.3 (c) and (e)

3.28.3 A propulsion engine required by Special Regulations shall:-

a) provide a minimum speed in knots of  $(1.8 \times \text{square root of LWL in metres})$  or  $(\text{square root of LWL in feet})$

b) have a minimum amount of fuel which may be specified in the Notice of Race but if not, shall be sufficient to be able to meet charging requirements for the duration of the race and to motor at the above minimum speed for at least 8 hours

c) have adequate protection from the effects of heavy weather

d) when an electric starter is the only method for starting the engine, have a separate battery, the primary purpose of which is to start the engine

e) have each fuel tank provided with a shutoff valve. Except for permanently installed linings or liners, a flexible tank is not permitted as a fuel tank.

### **3.28.4 Batteries**

*b) It is recommended that consideration be given to the installation of sealed batteries, noting however that a special charging device may be specified by the battery manufacturers*

### **3.29 Communications Equipment, EPFS (Electronic Position-Fixing System), Radar, AIS**

*Provision of GMDSS and DSC is unlikely to be mandatory for small craft during the term of the present Special Regulations However it is recommended that persons in charge include these facilities when installing new equipment.*

3.29.1 The following shall be provided:

a) A marine radio transceiver (or if stated in the Notice of Race, an installed satcom terminal), and

i an emergency antenna when the regular antenna depends upon the mast.

b) When the marine radio transceiver is VHF:

i it shall have a rated output power of 25W

ii it shall have a masthead antenna, and co-axial feeder cable with not more than 40% power loss

*iii the following types and lengths of co-axial feeder cable will meet the requirements of OSR 3.29.1 (b)(ii): (a) up to 15m (50ft) - type RG8X ("mini 8"); (b) 15-28m (50-90ft) - type RG8U; (c) 28-43m (90-140ft) - type 9913F (uses conventional connectors, available from US supplier Belden); (d) 43-70m 140-230ft - type LMR600 (uses special connectors, available from US supplier Times Microwave).*

*iv it should include channel 72 (an international ship-ship channel which, by common use, has become widely accepted as primary choice for ocean racing yachts anywhere in the world)*

e) A hand-held marine VHF transceiver, watertight or with a waterproof cover. When not in use to be stowed in a grab bag or emergency container (see OSR 4.21)

f) Independent of a main radio transceiver, a radio receiver capable of receiving weather bulletins

i) An EPFS (Electronic Position-Fixing System) (e.g. GPS)

*3.29.2 Yachts are reminded that no reflector, active or passive, is a guarantee of detection or tracking by a vessel using radar.*

*a) The attention of persons in charge is drawn to legislation in force or imminent affecting the territorial seas of some countries in which the carriage of an AIS set is or will be mandatory for certain vessels including relatively small craft.*

## **SECTION 4 - PORTABLE EQUIPMENT & SUPPLIES for the yacht (for water & fuel see OSR 3.21 and OSR 3.28)**

### **4.01 Sail Letters & Numbers**

4.01.1 Yachts which are not in an ISAF International Class or Recognized Class shall comply with RRS 77 and Appendix G as closely as possible, except that sail numbers allotted by a State authority are acceptable .

4.01.2 Sail numbers and letters of the size carried on the mainsail must be displayed by alternative means when none of the numbered sails is set.

### **4.03 Soft Wood Plugs**

Soft wood plugs, tapered and of the appropriate size, shall be attached or stowed adjacent to the appropriate fitting for every through-hull opening.

### **4.04 Jackstays, Clipping Points and Static Safety Lines**

4.04.1 The following shall be provided:

a) Jackstays:-

shall be provided-

i attached to through-bolted or welded deck plates or other suitable and strong anchorage fitted on deck, port and starboard of the yacht's centre line to provide secure attachments for safety harness:-

ii comprising stainless steel 1 x 19 wire of minimum diameter 5 mm (3/16 in), or webbing of equivalent strength;

iii which, when made from stainless steel wire shall be uncoated and used without any sleeving;

*iv 20kN (2,040 kgf or 4,500 lbf) min breaking strain webbing is recommended;*

#### **4.04.2 Clipping Points:-**

shall be provided-

a) attached to through-bolted or welded deck plates or other suitable and strong anchorage points adjacent to stations such as the helm, sheet winches and masts, where crew members work for long periods:-

b) which, together with jackstays and static safety lines shall enable a crew member-

i to clip on before coming on deck and unclip after going below;

ii whilst continuously clipped on, to move readily between the working areas on deck and the cockpit(s) with the minimum of clipping and unclipping operations.

c) The provision of clipping points shall enable two-thirds of the crew

to be simultaneously clipped on without depending on jackstays

*e) Warning - U-bolts as clipping points - see OSR 5.02.1(a)*

#### **4.05 Fire Extinguishers**

Shall be provided as follows:

4.05.1 Fire extinguishers, at least two, readily accessible in suitable and different parts of the yacht

#### **4.06 Anchor(s)**

4.06.1 An anchor or anchors shall be carried according to the table below:

a) The following anchors shall be provided

i) For yachts of 8.5 m LOA (28 ft) and over there shall be 2 anchors together with a suitable combination of chain and rope, all ready for immediate use

ii) For yachts under 8.5 m LOA (28 ft) there shall be 1 anchor together with a suitable combination of chain and rope, all ready for immediate use

#### **4.07 Flashlight(s)**

4.07.1 The following shall be provided:-

a) a watertight, high-powered flashlight or spotlight, with spare batteries and bulbs, and

b) a watertight flashlight with spare batteries and bulb

#### **4.08 First Aid Manual and First Aid Kit**

4.08.1 A suitable First Aid Manual shall be provided

*In the absence of a National Authority's requirement, the latest edition of one of the following is recommended:-*

*b) First Aid at Sea, by Douglas Justins and Colin Berry, published by Adlard Coles Nautical, London*

*c) Le Guide de la medecine a distance, by Docteur J Y Chauve, published by Distance Assistance BP33 F-La Baule, cedex, France. An English translation may be available.*

4.08.2 A First Aid Kit shall be provided

*4.08.3 The contents and storage of the First Aid Kit should reflect the guidelines of the Manual carried, the likely conditions and duration of the passage, and the number of people aboard the yacht.*

4.08.5 At least one member of the crew shall be familiar with First Aid procedures, hypothermia and relevant communications systems (see OSR 6.02.7, 6.03.3, 6.03.4)

#### **4.09 Foghorn**

A foghorn shall be provided

#### **4.10 Radar Reflector, AIS (Automatic Identification System)**

4.10.1 A passive Radar Reflector (that is, a Radar Reflector without any power) shall be provided

a) If a radar reflector is octahedral it must have a minimum diagonal measurement of 456 mm (18in), or if not octahedral must have a documented RCS (radar cross-section) of not less than 10 m<sup>2</sup>. The minimum effective height above water is 4.0 m (13 ft).

*b) The passive and active devices referred to in these notes and in 4.10.1 and 4.10.2 above are primarily intended for use in the X (9GHz) band*

*4.10.2 The most effective radar response from a yacht may be provided by an RTE (Radar Target Enhancer) which may be on board in addition to the required passive reflector. An RTE should conform to Recommendation ITU-R 1176. An RTE is strongly recommended.*

*b) The display of a passive reflector or the operation of an RTE is for the person in charge to decide according to prevailing conditions.*

*4.10.3 A passive reflector in compliance with revised ISO8729 (revision in progress at 1/06) offers improved performance over earlier models and has a size typified by a cylinder of not more than weight 5kg, height 750mm and dia 300mm. When revised ISO 8729 is published the Special Regulations regarding radar reflectors will be reviewed and may be changed.*

*4.10.4 S (3GHz) band radar is often used by ships to complement X (9GHz) band radar. On S (3GHz) band a conventional reflector or RTE offers about 1/10 the response obtained on the X (9GHz) band.*

#### **4.11 Navigation Equipment**

##### **4.11.1 Charts**

Navigational charts (not solely electronic), light list and chart plotting equipment shall be provided

#### **4.12 Safety Equipment Location Chart**

A safety equipment location chart in durable waterproof material shall be displayed in the main accommodation where it can best be seen, clearly marked with the location of principal items of safety equipment.

#### **4.13 Echo Sounder or Lead Line**

4.13.1 An echo sounder or lead line shall be provided

#### **4.14 Speedometer or Distance Measuring Instrument (log)**

A speedometer or distance measuring instrument (log) shall be provided

#### **4.15 Emergency Steering**

4.15.1 Emergency steering shall be provided as follows:

a) except when the principal method of steering is by means of an unbreakable metal tiller, an emergency tiller capable of being fitted to the rudder stock;

b) crews must be aware of alternative methods of steering the yacht in any sea condition in the event of rudder loss. At least one method must have been proven to work on board the yacht. An inspector may require that this method be demonstrated.

#### 4.16 Tools and Spare Parts

Tools and spare parts, including effective means to quickly disconnect or sever the standing rigging from the hull shall be provided.

#### 4.17 Yacht's name

Yacht's name shall be on miscellaneous buoyant equipment, such as lifejackets, cushions, lifebuoys, lifeslings, grab bags etc.

#### 4.18 Marine grade retro-reflective material

Marine grade retro-reflective material shall be fitted to lifebuoys, lifeslings, liferafts and lifejackets. See OSRs 5.04, 5.08.

#### 4.22 Lifebuoys

4.22.1 The following shall be provided within reach of the helmsman and ready for instant use:

- a) a lifebuoy with a self-igniting light and a drogue or a Lifesling with a self-igniting light and without a drogue.

4.22.3 Each inflatable lifebuoy and any automatic device (eg pole and flag extended by compressed gas) shall be tested and serviced at intervals in accordance with its manufacturer's instructions.

4.22.4 Each lifebuoy or lifesling shall be fitted with marine grade retro-reflective material (4.18).

#### 4.23 Pyrotechnic and Light Signals

4.23.1 Pyrotechnic signals shall be provided conforming to SOLAS LSA Code Chapter III Visual Signals and not older than the stamped expiry date (if any) or if no expiry date stamped , not older than 4 years.

red parachute flares LSA III 3.1	red hand flares LSA III 3.2	orange smoke LSA III 3.3	race category
6	4	2	MoMu0,1
4	4	2	MoMu2,3
	4	2	Mo4
2	4	2	Mu4

TABLE 13

4.23.2 The following lights shall be provided and readily available for the purpose of collision avoidance:

- a) a watertight white torch (flashlight) with spare batteries and bulb
- b) a watertight, high-powered white spotlight (searchlight) with spare batteries and bulbs

#### 4.24 Heaving Line

a) a heaving line shall be provided 15 m - 25 m (50 ft - 75 ft) length readily accessible to cockpit.

*b) the "throwing sock" type is recommended - see Appendix D*

#### 4.25 Cockpit Knife

A strong, sharp knife, sheathed and securely restrained shall be provided readily accessible from the deck or a cockpit.

## 4.26 Storm & Heavy Weather Sails

### 4.26.1 Design

*a) it is strongly recommended that persons in charge consult their designer and sailmaker to decide the most effective size for storm and heavy weather sails. The purpose of these sails is to provide safe propulsion for the yacht in severe weather - they are not intended as part of the racing inventory. The areas below are maxima. Smaller areas are likely to suit some yachts according to their stability and other characteristics.*

### 4.26.2 High Visibility

*a) it is strongly recommended that every storm sail should either be of highly-visible coloured material (eg dayglo pink, orange or yellow) or have a highly-visible coloured patch added on each side; and also that a rotating wing mast used in lieu of a trysail should have a highly-visible coloured patch on each side*

### 4.26.3 Materials

a) aromatic polyamides, carbon and similar fibres shall not be used in a trysail or storm jib but spectra/dyneema and similar materials are permitted.

*b) it is strongly recommended that a heavy-weather jib does not contain aromatic polyamides, carbon and similar fibres other than spectra/dyneema.*

### 4.26.4 The following shall be provided:-

- a) sheeting positions on deck for each storm and heavy-weather sail;
- b) for each storm or heavy-weather jib, a means to attach the luff to the stay, independent of any luff-groove device. A heavy weather jib shall have the means of attachment readily available. A storm jib shall have the means of attachment permanently attached;
- c) when a storm trysail is required by OSR 4.26.4 (g) it shall be capable of being sheeted independently of the boom with area not greater than 17.5% mainsail luff length x mainsail foot length. The storm trysail shall have neither headboard nor battens, however a storm trysail is not required in a yacht with a rotating wing mast which can adequately substitute for a trysail;
- d) if a storm trysail is required by OSR 4.26.4 (g) the yacht's sail number and letter(s) shall be placed on both sides of the trysail (or on a rotating wing mast as substitute for a trysail) in as large a size as practicable;
- f) a heavy-weather jib (or heavy-weather sail in a yacht with no forestay) of area not greater than 13.5% height of the foretriangle squared and without reef points;
- g) either a storm trysail as defined in OSR 4.26.4(c), or mainsail reefing to reduce the luff by at least 40%.

*i) It is strongly recommended that the heavy-weather jib does not contain aromatic polyamides, carbon fibres and other high modulus fibres.*

## SECTION 5 - PERSONAL EQUIPMENT

### 5.01 Lifejacket

5.01.1 Each crew member shall have a lifejacket as follows:-

- a) equipped with a whistle
- b) fitted with marine grade retro-reflective material (OSR 4.18)
- c) compatible with the wearer's safety harness
- d) if inflatable, regularly checked for air retention
- e) clearly marked with the yacht's or wearer's name

5.01.2 A lifejacket shall have:

- a) at least 150N buoyancy, arranged to securely suspend an unconscious man face upwards at approximately 45 degrees to the water surface - in accordance with ISO 12402 - 3 (level 150) or equivalent (for persons of larger than average build the ISO 12402 - 2 (level 275) jacket should be considered);
- b) a crotch strap or thigh straps;
- c) a lifejacket light in accordance with SOLAS LSA code 2.2.3 (white, >0.75 candelas, >8 hours);
- d) if inflatable have a compressed gas inflation system.

*It is strongly recommended that a lifejacket has:*

- e) a splashguard/sprayhood See ISO 12402 - 8;*
- f) A PLB unit (as with other types of EPIRB, should be properly registered with the appropriate authority)*

### 5.02 Safety Harness and Safety Lines (Tethers)

5.02.1 each crew member shall have a harness and safety line that complies with EN 1095 (ISO12401) or equivalent with a safety line not more than 2m in length

- a) Warning it is possible for a plain snaphook to disengage from a U-bolt if the hook is rotated under load at right-angles to the axis of the U-bolt. For this reason the use of snaphooks with positive locking devices is strongly recommended***

5.02.2 At least 30% of the crew shall each, in addition to the above be provided with either:-

- a) a safety line not more than 1m long, or
- b) a mid-point snaphook on a 2m safety line

5.02.3 A safety line purchased in January 2001 or later shall have a coloured flag embedded in the stitching, to indicate an overload. A line which has been overloaded shall be replaced as a matter of urgency.

5.02.4 A crew member's lifejacket and harness shall be compatible

*5.02.5 It is strongly recommended that:-*

- a) static safety lines should be securely fastened at work stations;*
- b) a harness should be fitted with a crotch strap or thigh straps;*
- c) to draw attention to wear and damage, stitching on harness and safety lines should be of a colour contrasting strongly with the surrounding material;*
- d) snaphooks should be of a type which will not self-release from a U-bolt (see OSR 5.02.1(a)) and which can be easily released under load (crew members are reminded that a personal knife may free them from a safety line in emergency);*
- e) a crew member before a race should adjust a harness to fit then retain that harness for the duration of the race.*

*5.02.6 Warning - a safety harness is not designed to tow a person in the water and it is important that a harness is used to minimise or eliminate the risk of a person's torso becoming immersed in water outside the boat. The diligent use of a properly adjusted safety harness is regarded as by far the most effective way of preventing man overboard incidents.*

#### **5.04 Foul Weather Suits**

- b) it is recommended that a foul weather suit should be fitted with marine-grade retro-reflective material, and should have high-visibility colours on its upper parts and sleeve cuffs. See OSR 4.18*

## **SECTION 6 – TRAINING**

### **6.04 Routine Training On-Board**

*6.04.1 It is recommended that crews should practice safety routines at reasonable intervals including the drill for man-overboard recovery*

## **APPENDICES TO SPECIAL REGULATIONS**

Appendix A - Minimum Specification for Yachtsmens Liferrafts

Appendix B - A guide to ISO and other Standards

Appendix C - Standard Inspection Card

Appendix D - Quickstop & Lifesling

Appendix E - Hypothermia

Appendix F - Drogues and sea anchors

Appendix G - Model Training Course

Appendix H - ISAF Code for the organisation of Oceanic Races

Appendix J - Category 5

Appendix K - Moveable and Variable Ballast

**Appendix L - Category 6**

Tue 18 Dec 07 14:13:40